

**ENVIRON CARE**

**2020**

**NEW  
PRODUCT**

# Air Disinfection Box to Fight Virus

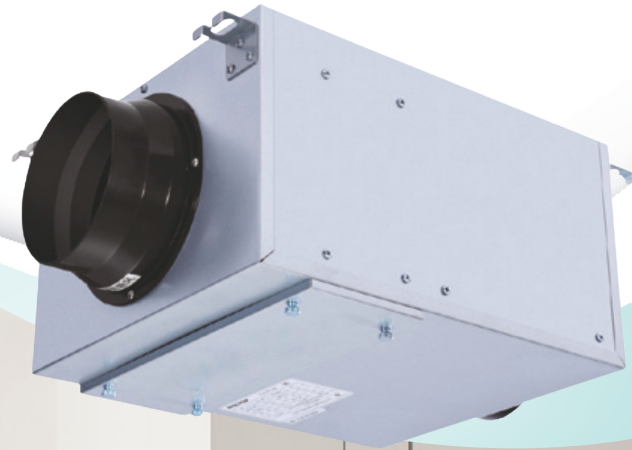

**Environ Care air disinfection box,**  
a great weapon in the fight for cleaner air and  
better health

**Environ Care Co., Ltd.**

Environcare\_th@yahoo.com

www.environcare.com



## AIR DISINFECTION BOX

### Medical UVC Germicidal Lamp

Environ Care customized ultraviolet germicidal lamp can concentrate high intensity to kill bacteria and viruses in a short time.

The wavelength of 254nm is easily absorbed by living organisms.

The DNA or RNA, which acts on the organism's genetic material, destroy the DNA/RNA to kill the bacterial and virus.

**10000 HOURS**

Average lamp lifetime to 10000 Hours

**UV<25%**

Low UV depreciation: less than 25%, after 8000 hrs working time, the lead of domestic products



Full DNA

Destroyed DNA

### Medical Photocatalytic Filter

The germicidal UVC light irradiates the photocatalytic material (dioxygentitanium oxide) to combine water and oxygen in the air for photocatalytic reaction, which will quickly produce high concentration of advanced germicidal ion groups (hydroxide ions, superhydrogen ions, negative oxygen ions, hydrogen peroxide ions, etc.). The oxidizing and ionic properties of these advanced oxidation particles will decompose the chemically harmful gases and odors quickly, subside the suspended particulate matters, and kill the microbial contaminants such as viruses, bacteria, and mold.

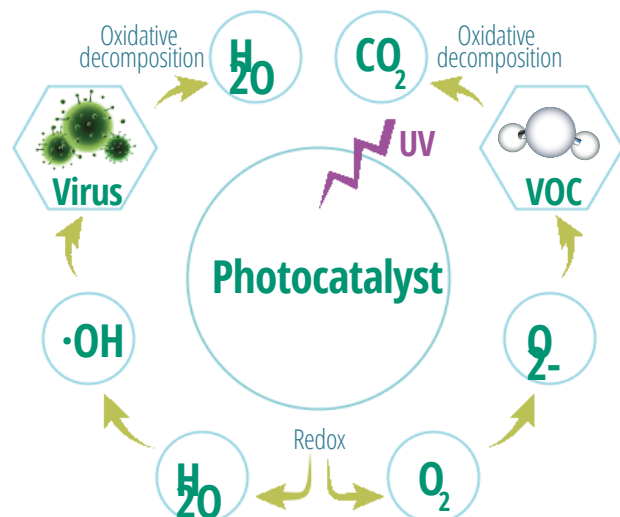

## AIR DISINFECTION BOX

### Features

- Efficient inactivation**  
 Kill the virus in the air in a short time, greatly reducing the possibility of virus transmission.
- Full initiative**  
 A variety of purification ions are generated and emitted to the entire space, and various harmful pollutants are actively decomposed, which is efficient and comprehensive.
- Zero pollution**  
 No secondary pollution and zero noise.
- Reliable and convenient**
- High quality, convenient installation and maintenance**

**Application: residential house, small office, kindergarten, school and other places.**

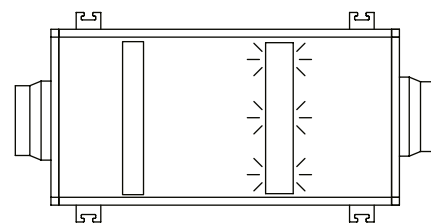
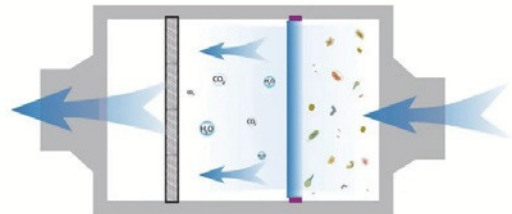

Medical Photocatalyst Sterilization Filter

Medical UV germicidal lamp

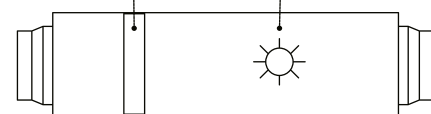

## Environ Care Air Disinfection Box Has Been Tested By Third Party



EMC / LVD / FCC



Germicidal Efficacy Report

Staphylococcus albus (ATCC 8032) / streptococcus pneumonia (ATCC 49619) / Influenza A virus H1N1(A/PR/8/34) Host cell: MDCK  
 Sterilization rate **>99.9%**



## AIR DISINFECTION BOX

### Specifications

Model	Air volume (m3/h)	Resistance (Pa)	Power supply (V)	Power (W)	Net weight (kg)
HUV-100	≤ 350	4	220	4	5.4
HUV-150	≤ 400	4	220	4	5.4
HUV-200	≤ 600	5	220	6	7.4
HUV-250	≤ 1300	5	220	6	7.8

Model	Air volume (m3/h)	Resistance (Pa)	Power supply (V)	Power (W)	Net weight (kg)
HUV-100A	≤ 350	4	110-120	4	5.4
HUV-150A	≤ 400	4	110-120	4	5.4
HUV-200A	≤ 600	5	110-120	6	7.4
HUV-250A	≤ 1300	5	110-120	6	7.8

### Control

- The air disinfection box can be used in conjunction with energy recovery ventilator, and work together with interlock control.
- The disinfection box can be used independently with ON/OFF controller with optional button controller or touch screen controller.

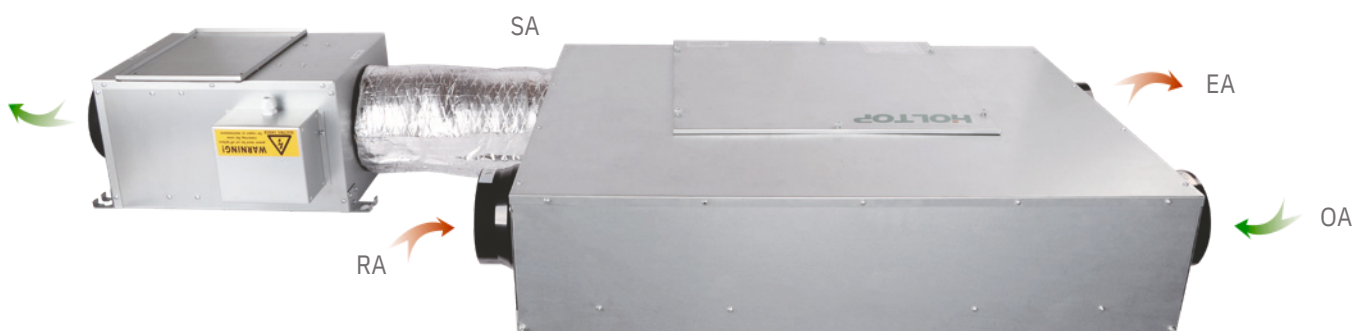



## AIR DISINFECTION BOX

### Installation Instructions

- Air disinfection box can be used in conjunction with energy recovery ventilator, and work together with interlock control.
- Air disinfection box can sterilize the outdoor or indoor polluted air.
- Air disinfection box is recommended to be installed on the air supply and exhaust ducts first.
- Both ends of air disinfection box need to be connected to the main pipe with hoses.

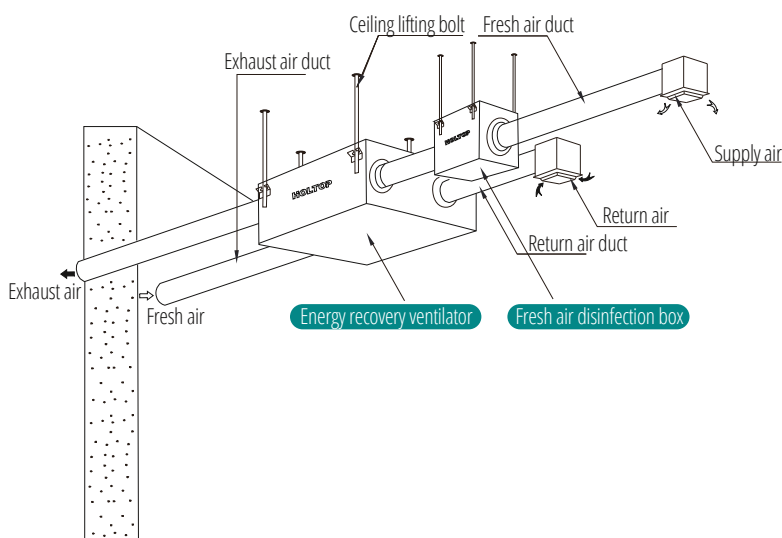

### Customized model matching with ducted FCU & AHU

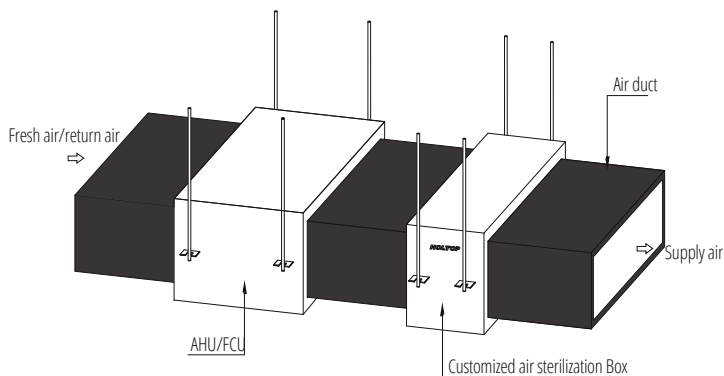

Ducting Schematic

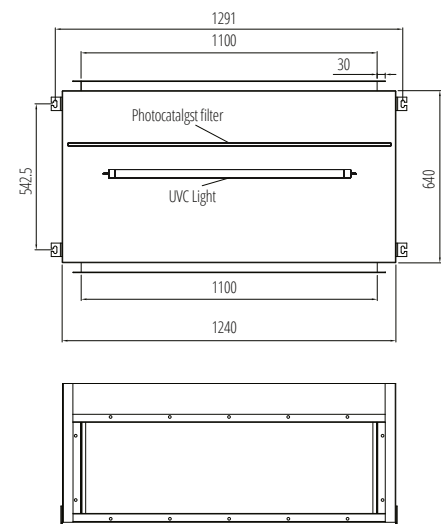

Customized Sterilization Box

# Contact us

Line ID : @environcare

Facebook : Environ Care Thailand

www.environcare.co.th

Direct Line : +66 092 4894064

**ENVIRON CARE CO.,LTD.**

3798/124 Ladprao 101 Soi, Klongjan,  
Bangkapi, Bangkok 10240

Tel : +66 2736 8515 (Auto), +66 2736 8277

Fax : +66 2736 9883



environ  
care

